

ROLE AND IMPORTANCE OF TECHNOLOGY DEVELOPMENT AND IMPROVEMENT EMERGENCY ASSISTANCE AND SUSTAINABLE DEVELOPMENT AND ENVIRONMENTAL PROTECTION IN ROMANIA

Ionel NUTA

*National Institute of Economic, Bucharest, Romania
nuta_ionel2014@yahoo.com*

Abstract

Year 2014 was considered by NASA and NOAA hottest year in history. Combined temperature of the atmosphere and oceans has increased overall by 0.68 degrees Celsius, and the devastating effects of climate changes produced irreversible consequences on the sustainability of the planet earth.

Increasing the frequency, intensity and complexity of their manifestation caused initiation and development of global policies aimed at mitigating climate change priority, reducing the risk of natural disasters or anthropological costs and negative effects to society and the environment.

In order to fulfill the responsibilities assumed by Romania as a member of international bodies is necessary to search and apply new solutions as revolutionary and effective, especially autonomous enabling technology development and improvement of emergency intervention and replacement of emergency autonomous robotic systems.

Autonomous robotic systems allow execution of prevention and management of emergencies in areas difficult to reach, hostile life and result in increasing their efficiency.

Key words: *sustainable development; natural disaster risk reduction; climate change; emergency; technical intervention in emergencies.*

JEL Classification: *Q01, Q54, Q55*

I. INTRODUCTION

Revolution of 1989, has pioneered modern history of Romania and reconstruction of political, economic and diplomatic neighbors domestic and international structures. Thus, Romania, on 29 March 2004 is a NATO member, and from 1 January 2007, a member of the European Union.

These achievements have assumed that Romania to go through an extensive and complex process changes and reforms, with a legislative framework, politically, economically and socially developed organic and coherent methodology and procedures for aligning said structural requirements.

Thus, in the context mentioned geostrategic and multiplication, non-military risks to national security, amid accelerating globalization trends, the radical climate change, the development of scientific experiments with unpredictable effects, the legal diversification of economic activities using produce and sell dangerous substances to ensure the consistent and defense and professional life and health, the environment, material and cultural values important and rapid restoration of normality, in 2004, was established the National System of Management of Emergency Situations. The system is composed of National Committees for emergency situations, the General Inspectorate for Emergency Situations, professional community public services for emergencies, emergency operational centers and master action.

National Committee to ensure fulfillment of the specific duties in line to achieve the objectives Romania International Strategy for Disaster Reduction until 2014, when due to complex emergencies, and developed markedly in recent years (floods, landslides, falling edge snow, hail, forest fires and especially aviation accidents in 2014), the multiple coordination and cooperation in their management proved inadequate.

Therefore, to improve information management and integrated management actions taken in emergency situations, in 2014 to set up emergency department. National Committee for Emergency Situations is replaced by two specialized committees, namely:

- National Committee for weather and disasters;
- National Committee for Emergency Situations Special, which assume the duties of the National Committee for Emergency Situations new emergency department is an operational structure without legal personality, with coordination, permanent, national prevention activities and emergency management, which provides and coordinates human, material, financial and other resources necessary to restore normal state, including first aid

and emergency care qualified in the units and emergency departments receiving UPU / CPU, General admission to spital.

Inspectoratul for Emergencies is a specialized body that provides uniform and permanent coordination of the two main areas of activity prevention, and management of emergencies.

II. EMERGENCY PREPAREDNESS AND SUSTAINABLE DEVELOPMENT OF ROMANIA.

Emergency preparedness is an integrated set of specific technical and operational, planned and executed to eliminate / reduce disaster risks in order to protect life, property and the environment against adverse effects of emergencies.

Has anticipatory result set consisting of graduated measures for prevention targeted events. World practice has shown that emergency generators events can not be avoided, but sometimes they can be managed, and their effects can be reduced through a systematic process that involves the establishment of measures and actions to help mitigate the risks associated these phenomena. Characteristic of emergency management is that predictability place of manifestation of such situations can determine potential areas warning people to be affected and the central public authorities and / or local.

Emergency management is the application of policies, procedures and practices with the objectives of identifying, analyzing, evaluating, treating, monitoring and reassessment of risks to reduce them so that human communities and citizens can live, work and to satisfy the needs and aspirations in a sustainable physical and social environment.

The strategy is based on the following principles:

- Supremacy protection of citizens. According to the Romanian citizens enjoy constitutional protection of the state, both on national territory and abroad, and emergency preparedness is a specialized function of the state.
- Sustainable development. Emergency preparedness subsumed sustainable development, conceived as coordinated development of processes that allow continuous progress on planning and mobilizing existing resources reconciling the objectives of economic, social and environmental aspects of society, in the short and long term, due to the implementation of mutually reinforcing strategies.
- Complementarity prevention and response. Prevention and response are complementary, the character of the process and constitute a permanent activity of national and international importance and responsibility.
- The importance of prevention of emergency situations. As is commonly recognized, internationally, that prevention is at least eight times less costly than reacting to events products, emergency preparedness should be a priority activity.
- The obligation to prevent emergencies. Pregnancy prevention of emergency situations is complex and interdependent. It involves responsibilities of citizens, local communities, economic operators and public authorities and is managed by all components of the National Management System for Emergency Situations.
- Identifying, assessing and prioritizing risks. In this process, the identification, evaluation and ranking of risk, based on a profound knowledge, must take into account the maximum level of their expression, simultaneity and their carrying chain that makes the planning issues to consider as each party risk and situations or inter-combined event in order to ensure a rapid response preparedness, protection and mitigation.
- Specialization. Risk identification, regulation, planning and organization of preventive measures is in the power performance of ministries and bodies with functions supporting the prevention and management of emergencies.
- The gradation. According to this important requirements in the field of prevention and emergency management decisions are made at several levels namely local, regional and national levels. Strengthening prevention and response at the local level is a priority.

III. EMERGENCY MANAGEMENT AND SUSTAINABLE DEVELOPMENT.

Emergency management is an activity of national interest which takes into account the frequency of production and size effects of types of risks generating emergency situations. This involves identifying and monitoring, notification stakeholders, warning the people, evaluation, limitation, prevention or mitigation of risk factors.

Limiting intervention, prevention or mitigation of risk factors is the main component of integrated technical and organizational measures planned and conducted to answer appropriate and qualified in emergency situations.

The intervention is based on the principle of individual and collective safety and operational efficiency principle. Performing surgery is performed mainly by the following operations:

- Driving at intervention;
- Recognition, situation analysis, decision-making and giving the order of intervention;
- Evacuation, rescue and / or protect people, animals and goods;
- Development, adaptation and completion of the intervention device to the concrete situation;

- Location and limit the effects of the event (disaster);

In conclusion, intervention technique used for the prevention and management of emergencies, has a special role and needs of developing and improving its gradual replacement with new specialized technical risk types of emergency generators and replace the human factor with robotic systems .

IV. TECHNOLOGY OF PREVENTION AND INTERVENTION IN EMERGENCIES AND SUSTAINABLE DEVELOPMENT.

Given the complexity, frequency, extent and consequences of particular emergencies, prevention and intervention in these situations is increasingly becoming an integral part of development policies and strategies, security and stability at all levels and in all areas of interest.

In both fields the primary role plays man who must travel on site, analyze, and make decisions of life and death for resolving emergencies. Unfortunately no matter how well prepared it has its limits.

Therefore, research efforts in recent years has been directed mainly in the direction of meeting the requirements of replacing human personnel to carry out missions with high-risk environments difficult to control, along with the pace of progress in the field of mechatronics, optoelectronics, electronics and computing power have allowed providing specialized market of existing technologies in civil and military applications needed to achieve this goal.

One solution is the development of specialized robots families for prevention and intervention, capable of movement in the affected areas before the emergency to develop and out of control, to save life and property or to get a detailed view transmitting human data and information necessary to respond effectively. Autonomous robotic systems are designed as interchangeable operational mobile platforms able to travel over rough terrain and transport superstructures (modules) specialist.

At the moment there is IGSU equipment such robotic platform with interchangeable modules, especially for data collection and information to prevent and extinguish fires at targets at risk of major accidents involving dangerous substances (nuclear power plants, chemical plants or petrochemicals, etc.) (Figure1.).

Based on these considerations and the fact that intervention technique endowment General Inspectorate for Emergency Situations and intervention units consists usually of high capacity vehicles propelled by internal combustion engines and 50% of them are older than 20 years (Raed Arafat, 2014) in terms of a highly diversified field of magnitude larger fire on a front random wind direction and speeds over 40 km / h, the capacity of intervention them is severely limited. Approaching the outbreak or even fire area subjected to considerably reduce system stability and during intervention of intervention.

In this sense, innovation is to build an experimental model as a basis for further development of autonomous mobile robots families to prevent and response to emergencies, especially for a particular area by frequency and consequences of the fire. The experimental model is a mobile platform which is an essential element of a family of robots made in a modular and flexible design, and has the capacity to respond effectively to changing circumstances that state action so that the same platform can work together more many types of specialized superstructures (TARC Radu, 1999) (Figure 2).

The modular concept of the experimental model is characterized by:



Fig.1. Intervention at an objective risk of major accidents involving dangerous substances

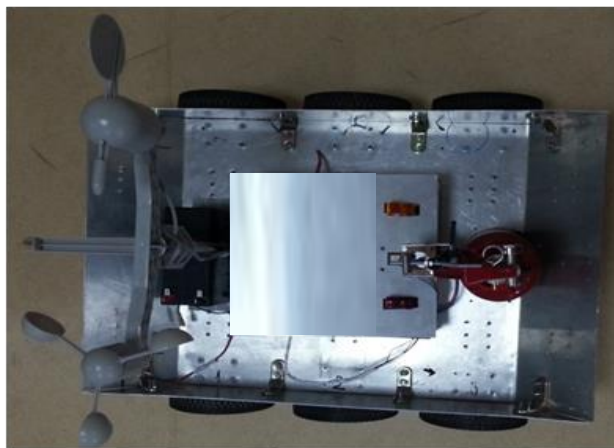

Fig. 2. Experimental model

- Systematic structure is composed of a group of systems and devices that form the ruling kinematic couplings and provides the information necessary to analyze the kinematic and dynamic mechanical drive systems and robot. It has the disadvantage that only partially reflect the functions of the robot and junior construction features thereof;

- The modular structure is guiding devices with serial topology to highlight the functional and structural properties of the robot (robot mode). Module robot kinematic coupling correlated with the ruling parties have "fixed" the drive for the kinematic coupling leading and transducers / sensors, integral with one of the resistance of the elements. The connection between two neighboring modules is achieved through structural frame element. In this way, the entire robot consists of "series connection" of a number of core modules and auxiliary;

- Functional structure - design with standard modules, which is a further constructive concept dezvoltarte with their typical modules. Are a subset of the standard module by itself interchangeable with other modules as part of a series of standard modules that can be assembled with other modules in a design standard "baukasten", forming a family of robots composed of standard modules, depending on the emergency or after user requirements.

Concept flexible experimental model is characterized by the following categories:

- The use, which has the capacity to allow a certain number of tasks for a variety of tasks for prevention and intervention;

- adapting to different tasks of prevention and intervention and assessed value. The greater flexibility to adapt the system more flexible. Adaptation is achieved by transformation (replace with other functional elements), modification (selection for a particular process of functional elements of existing lots), installation (altering the characteristics of functional elements) and re;

- For redundancy, which has the capacity to have more funds available for the same task in several variants of the route of intervention;

- The structural change that has the ability to alter the structure, depending on the activities conducted: expansion, restructuring, modifying work sites manipulators;

- Programming, which has the ability to accept control software, management, navigation, data collection and processing information and a large variety of many programs.

The robot is made of 6x6 transmission platform independent, self-sufficient energy, wireless remote controlled using a PC. The system allows remote control of the 6 motors attached to the robot using a joystick connected to the PC or directly from a laptop. The robot has a camera attached to the PC to transmit video stream, video stream will be displayed in a robot control software created specifically for this purpose. Also, the robot is attached to a series of sensors, information gathered by them being transmitted and displayed on the PC.

The position of the robot in space will be monitored by a GPS system placed on the machine, and inertial navigation system. Data from these two systems will be sent to the PC located in dispatching emergency inspectorates being used to display the position and orientation of the robot in space (Figure 3.).

Configuring robotic system.

Configuring robotic system was based on the need to work and act in various circumstances, environments, locations, and at any time of day (night / day), as follows:

- Be autonomous in terms of energy;
 - To enable remote command and control;
 - Explore environment, locate victims and to detect dangerous substances in the critical area;
 - Submit data and information necessary for the prevention, decision making, intervention and rescue victims;
 - be able to independently change the position to avoid damaging the equipment;
 - Be able to handle and carry accessories necessary intervention;
 - To allow rapid adaptation and change modules and accessories according to the job that has to perform;
 - Lightweight mobile robot's components;
 - Service and maintenance easy and cost-effective;
- Configuring considered optimal for achieving the objectives set is as follows:

- Platform based robot.

- Drive a 6x6 all-terrain wheels.
- Transmission System a metal gearbox Motor 37DX52L mm and encoder feedback control of movement;



Fig.3. Dispatch I.G.S.U.

- 37D mm metal support;
- A wheel motor connector 6 mm.
- Processing Platform
 - Arduino UNO an open source.
- The board microcontroller.
 - Arduino Mega 2560 one based on the ATmega2560;
- Platform for gathering information an environmental sensors.Weather Station:
 - Wind direction and speed;
 - Smoke and gas MQ- 2;
 - Methane MQ - 4;
 - GPL MQ - 6;
 - Carbon monoxide MQ -7;
 - Pressure BMP 085;
 - Moisture HIH 4030;
 - Infrared MLX 90614.
 - GPS sensor:
 - EM 406A GPS with 20 channel SIRF III 02;
 - GPS shield.
 - An inertial navigation sensors
 - Stick 9 degrees.
- PC control system.
 - A computer control system to the PC will consist of a software application designed and implemented specifically for this purpose.
 - The PC will display a video stream received from the robot, it will display information collected by sensors environment will display a model of the robot to highlight its position and orientation in space, and send the user information generated by the robot to control the position thereof.
- Robot control system.
 - A robot control system includes a feedback system using them encoder mounted engines, so the robot to maintain the same speed both horizontal and inclined.
- Wireless Control System
 - A wireless control system will be based on an XBee communication type.
- Operating system platform video
 - Video camera mounted on the robot, the camera will send wireless video stream to your PC via a USB TV tuner.
- Platform for fire fighting.
 - A specially quenching with carbon dioxide, nitrogen or water.
- Platform for towing.
 - An electrical and mechanical winches.
- Power Robot,a functional variant,
 - Electronics -1 X LiPo 12 V / 5.5 Ah
 - Engines -1 X LiPo 12 V / 5.5 Ah;
 - Li ion Polymer Charger 50W 5A.

The research is focused on the behavior and the experimental model in different situations platform. The



Figure 4. Testing of the experimental model.

construction and testing of the experimental model aims at the validation of a new concept, which is still in its infancy promoting (Figure 4). It must demonstrate the viability of solutions propeller 6x6 all-terrain, identify and solve problems that arise in cooperation with the land and propeller that can be analyzed and solved independently by the robot controller. The literature studied were not identified references on the use of specialized programs and assessment methodologies autonomous mobile robots. To implement the simulation model was used 6x6 vehicle for which experimental data able to validate simulation methods adopted aiming to identify operational requirements, in particular, those input data volume and functional sizes calculated.

Analysis autonomous mobility all-terrain

vehicles, regardless of the method chosen (theoretical research, experimental research, modeling, simulation) data should meet the needs of the real challenges (O.și Savu A. Orban, 2007). One of the features is the requirement of mobility tracked remotely.

The main requirements imposed simulation process are: high degree of generalization, the high degree of detail constructive flexibility to allow defining the types of terrain, obstacles, environmental conditions, ease of operation, capability of interfacing with dedicated software for data analysis.

These requirements often contradictory, become very complex under conditions of high temperature and wind direction fluctuations in the intervention technique works in emergencies. Statements characteristic simulation are:

- Turnover velocity field deformable, horizontal or longitudinal slopes max. 17%, with the direction of movement of viral ray straight and wide;
- Turnover in the field dimensionally stable, horizontal natural or artificial obstacles with rectilinear direction of movement briefly and small corner radii and gauge restrictions;
- Turnover in the field deformable horizontal longitudinal and transverse slopes with natural or artificial obstacles, the direction of movement rectilinear and variable radius bends. Functional parameters which determine the robot's autonomous mobility are: acceleration, manageability, crossing ability of different types of obstacles (Figure 5), ability orientation in the field (video, sound, etc.).

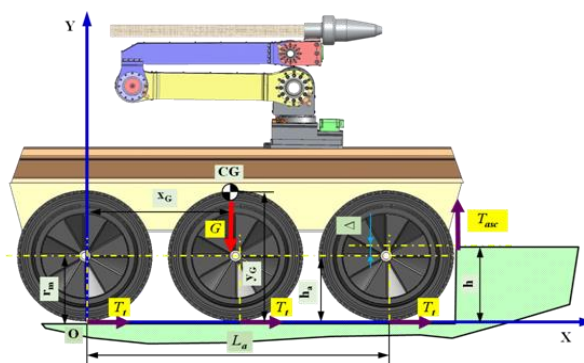

Fig.5. Level crossing barrier type.

V. CONCLUSIONS

Development and improvement technique for emergency intervention has a particularly important role in emergency management. Thus saving a life, save the planet but it must be prepared to face new challenges. Building the experimental model and analyze mobility in different situations, are related to increased performance over conventional systems with wheels and / or tracks, especially on uneven support surfaces, dotted with obstacles and critical areas, with the following advantages as follows:

- Reducing the number of victims and material goods;
- Reduce intervention time;
- Change the position of the base element relative to a fixed reference system considered linked to the supporting surface and providing information critical to its management of the emergency;
- Elimination of potential risk scenarios firefighter fatalities and creating the possibility to focus on jobs you have done to neutralize the dangers of fire and not to the immediate safety;
- Eliminate the risk of fire firefighter approach, given that ignition sources (hydropower elements) are unknown or do not know which is their situation in terms of temperatures reached, drafts, etc;
- Intervention in different parts of the environment in which they work, resulting in a considerable increase in the workspace and streamline operations reconnaissance, observation and inspection, analysis, decision making and implementing intervention device intervention;
- Preventing or overcoming obstacles on the supporting surface, moving stairs and other artificial surfaces and navigation around or above its major bumps independently;
- Elimination location sensors or devices in close proximity to sources of emergency generators, which are already implemented on the robot;
- Costs much less than those implied by the change of the machine or those related to the purchase of a new specialized robot.

By the prevention and management of emergencies, the General Inspectorate for Emergency Situations, actively participates in strengthening three interrelated pillars of sustainable development:

- Economic development;
- Social development;
- Environmental protection at local, national, regional and global levels.

VI. ACKNOWLEDGMENT

This paper has been financially supported within the project entitled “*Horizon 2020 - Doctoral and Postdoctoral Studies: Promoting the National Interest through Excellence, Competitiveness and Responsibility in the Field of Romanian Fundamental and Applied Scientific Research*”, contract number POSDRU/159/1.5/S/140106. This project is co-financed by European Social Fund through Sectoral Operational Programme for Human Resources Development 2007-2013. **Investing in people!**

VII. REFERENCES

1. Arafat Raedk, *Department for Evaluation of Emergency Situations*, March 2014, http://www.igsu.ro/documents/information_public/evaluation/assessment-DSU-2013.pdf;
2. Tarca Radu, *Flexible manufacturing systems*, page 10; http://imt.uoradea.ro/mecatronica/doc/flexible_manufacturing_systems.
3. Alecu, S. și Orban, O., 2006- *Robot pentru combaterea acțiunilor teroriste*. Ciolpani, România :Centrul Național pentru pregătire Apărare Civilă, 2006.
4. [PittmanE,2015,How Robots Are Changing Disaster Response and Recovery](http://www.emergencymgmt.com/disaster/How-Robots-Are-Changing-Disaster-Response-Recovery.html) <http://www.emergencymgmt.com/disaster/How-Robots-Are-Changing-Disaster-Response-Recovery.html>